

Collector Array Option 1

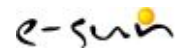

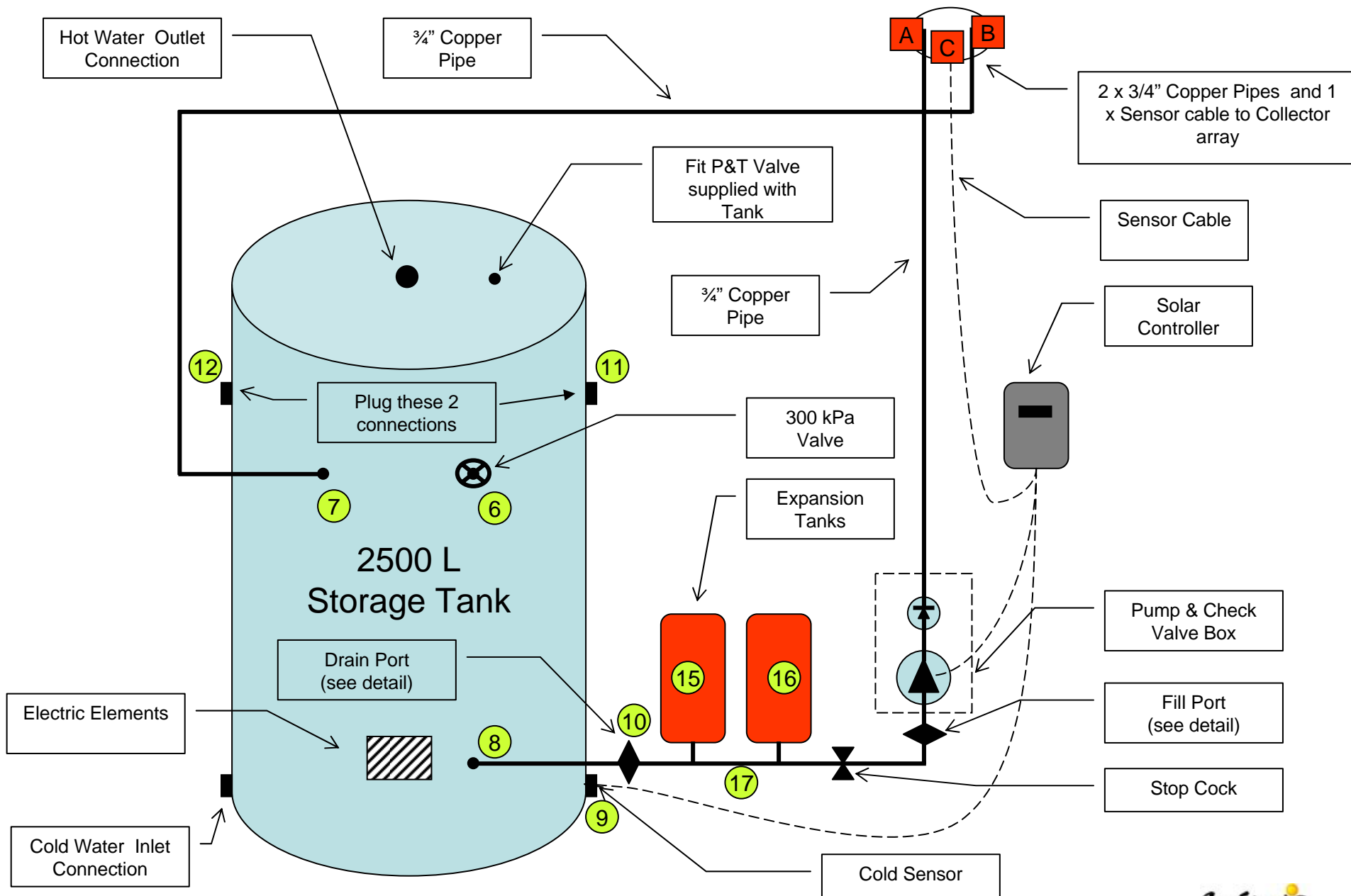

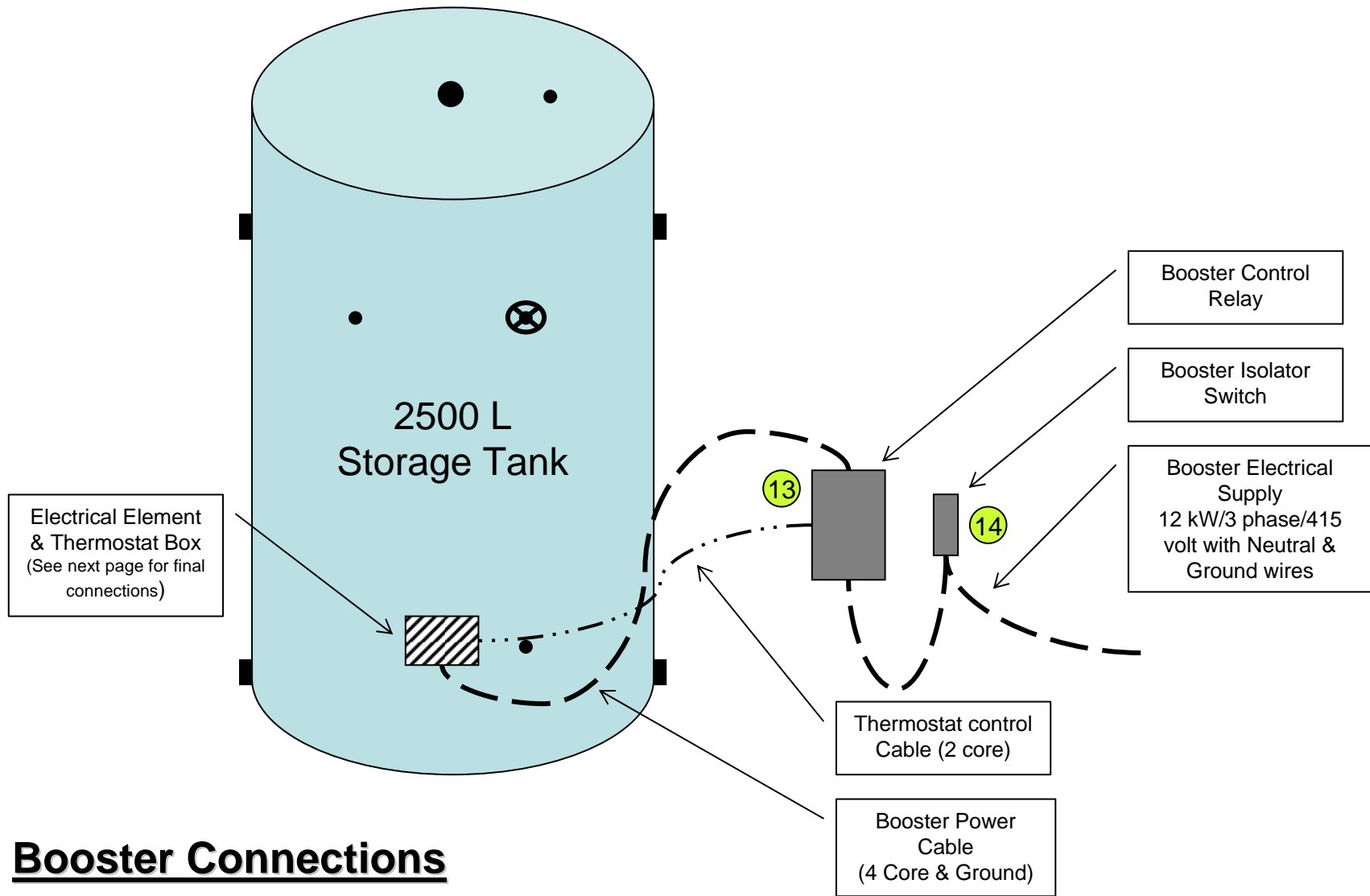

Booster Connections

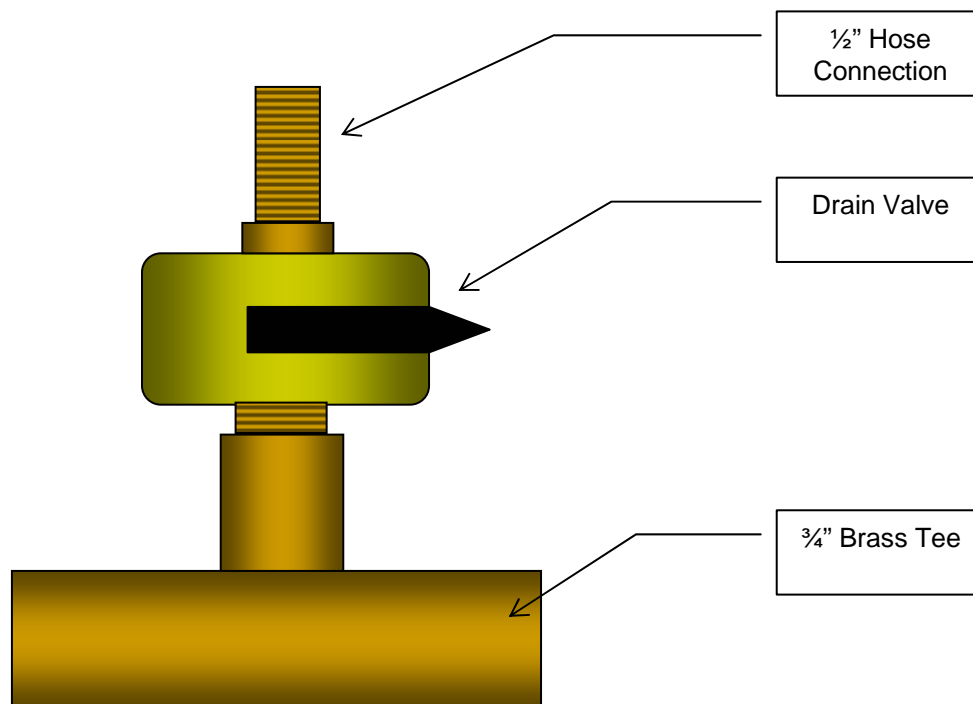

Drain and Fill Port Detail

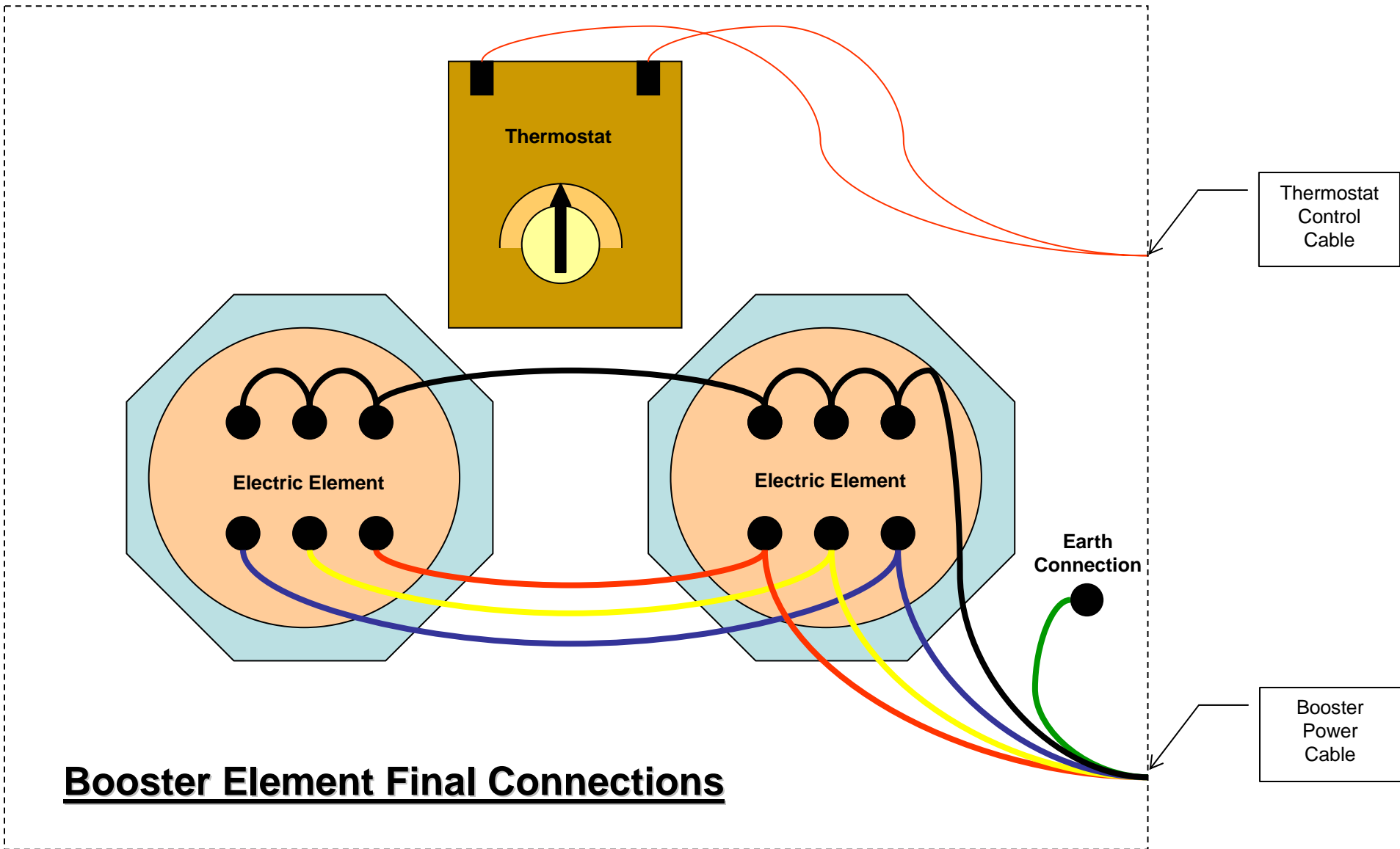



Element Electrical Connection Photograph



Finished metalwork around inspection plate



Finished metalwork around connection fittings



**Cut of transport cradle legs 20mm to 30 mm
from tank body**